

1013 Minivap 2



1014 Minivap 3



1230 Faber



- Line of portable steam generators with 800 W professional iron
- AISI 316 stainless steel pressure vessel with Safety Thermostat and Water refill Alert by lamp and buzzer
- Pressure gauge and pressure switch (Minivap 3 and Faber)
- Included accessories: Iron rest, Cable stand
- Linea di generatori di vapore portatili con ferro professionale 800W
- Caldaia in acciaio inossidabile AISI 316 con Termostato di Sicurezza e Segnalatore di esaurimento acqua acustico e luminoso
- Manometro e pressostato (Minivap 3 e Faber)
- Accessori inclusi: Tappetino poggiaferro, Asta reggicavo
- Serie tragbarer Dampferzeuger mit professionellem Bügeleisen 800W
- Kessel aus Edelstahl AISI 316 mit Sicherheitsthermostat, akustischem und optischem Signal bei Wassermangel
- Manometer und Druckschalter (Minivap 3 und Faber)
- Zubehör inklusive: Bügeleisenunterlage und Peitsche
- Ligne des générateurs de vapeur avec fer professionnel 800W
- Chaudière en acier inox AISI 316 avec thermostat de sécurité et indicateur de fin eau acoustique et lumineux
- Manomètre et pressostat (Minivap 3 et Faber)
- Accessoires inclus: Repose fer, Tige soutien câbles
- Línea de generadores de vapor portátiles con plancha profesional 800W
- Caldera en acero inoxidable AISI 316 con termostato de seguridad y indicador acústico y luminoso de agotamiento de agua.
- Manómetro y presostato (Minivap 3 y Faber)
- Accesorios incluidos: apoyo plancha y muelle soporte cables

DATI TECNICI	TECHNICAL SPECIFICATIONS	DONNEES TECHNIQUES	TECHNISCHE DATEN	DATOS TECNICOS	Minivap 2 1013	Minivap 3 1014	Faber 1230		
Alimentazione elettrica*	Electrical requirements*	Entrée courant*	Elektrischer Anschluss*	Alimentación eléctrica*	230V 50Hz 120V 60Hz	230V 50Hz 120V 60Hz	230V 50Hz		
Capacità caldaia	Boiler capacity	Capacité chaudière	Kesselinhalt	Capacidad caldera	2 l	3 l	5 l		
Pressione esercizio	Working pressure	Pression travail	Betriebsdampf-druck	Presion trabajo	250 kPa (2,5 bar)	250 kPa (2,5 bar)	250 kPa (2,5 bar)		
Potenza totale	Power consumption	Puissance nominale	Nennleistung	Potencia nominal	1550 W max	1850 W max	2250 W max		
Resistenza caldaia	Boiler heating element	Résistance chaudière	Kesselwiderstand	Resistencia caldera	700 W	1000 W	1400 W		
Resistenza ferro	Iron heating element	Résistance fer	Bügeleisenelement	Resistencia plancha	800 W	800 W	800 W		
Peso netto	Net weight	Poids net	Netto Gewicht	Peso neto	8 kg	10 kg	15 kg		
Peso lordo (cartone)	Gross weight (carton)	Poids brut (carton)	Brutto Gewicht (Karton)	Peso bruto (cartón)	9 kg	11 kg	17 kg		
Dimensioni imballo	Packaging size	Dimensions emballage	Verpackungsmasse	Dimensiones embalaje	46x27x33cm 18"x11"x13"	48x31x48 cm 19"x12"x19"	32x48x50 cm 13"x19"x20"		
* Altri a richiesta		*Others available		*Autres sur demande		*Andere auf Wunsch		*Otros por petición	
Con riserva di modifica senza preavviso - Subject to modification w/o									

Accessories - Accessori - Zubehör - Accessoires - Accesorios

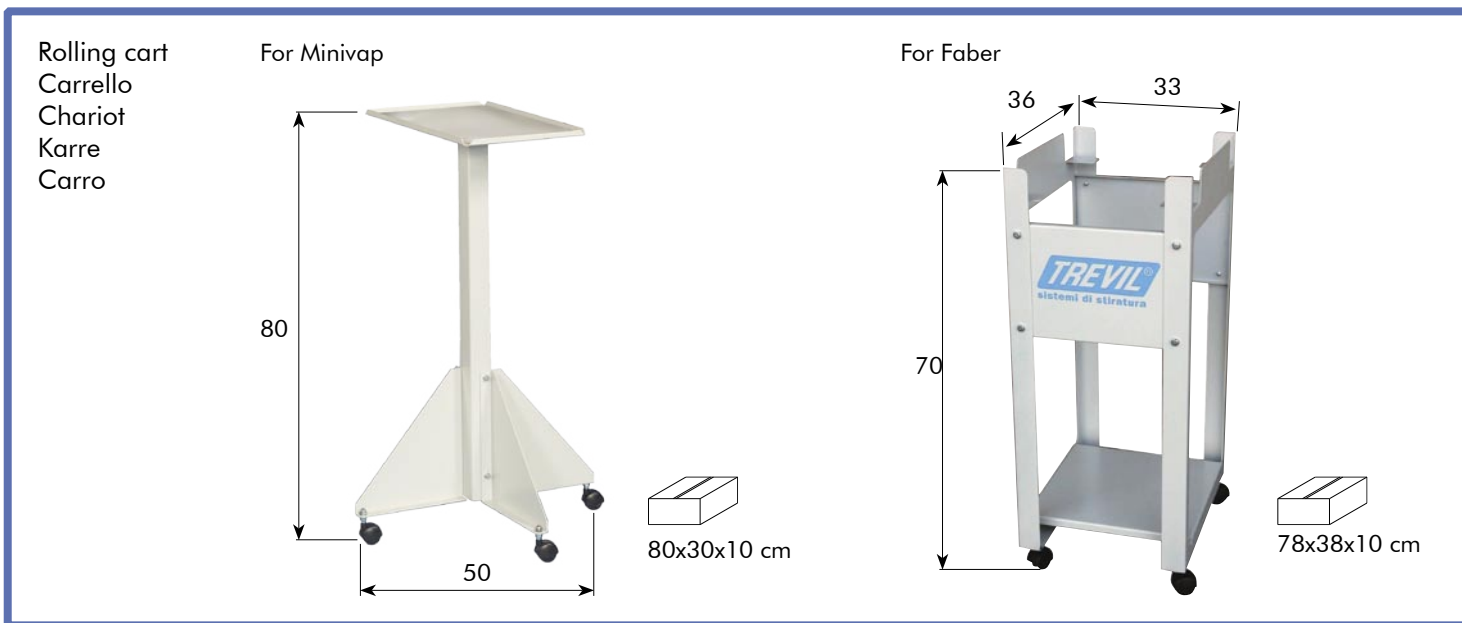

TREVIL